

# MoNo Clipper

Packaging machine



The MoNo Clipper packaging machine uses a PE label to seal the tubular net. It has an automatic tube changer that enables a continuous supply of net. This variant is more sustainable and requires less maintenance than the conventional Clipper because it doesn't need a clip magazine or oil. The integrated labeler supports strip, wine glass, and seal-to-seal labels.

## Features

- The tubular PE net is closed with a SEAL using a PE label
- Cost effective: only 2 consumables instead of 3 (no metal or plastic clip)
- Mono material bags that are easy to recycle
- Accepts both knitted and extruded mesh materials
- Integrated labeler works with both wine glass and strip labels and can easily switch for different packages
- Optional printing for product identification
- Automatic tube exchange to continue operation while tube netting is refilled

# MoNo Clipper

Packaging machine

Specifications	Values
Packing range:	0.25 - 2 kg*
Diametre nettube:	160 - 200 (default)
Capacity at 1kg up to:	30 bags/min*
Air consumption: (conditioned dry air)	450 L/min
IP-rating	IP54
Supply voltage	3x 400V/50Hz+N+GND
Power consumption:	4 kW
Weight of the machine:	650 kg

\*Depending on product, packaging type and other possible factors.

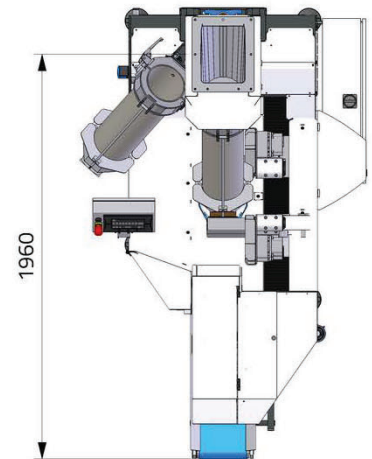
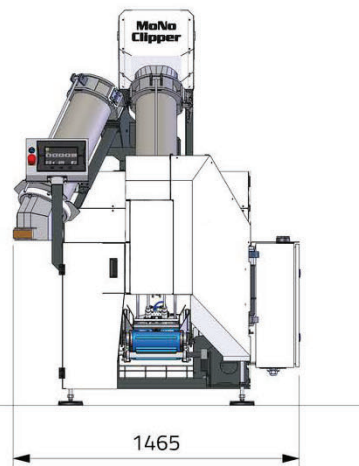
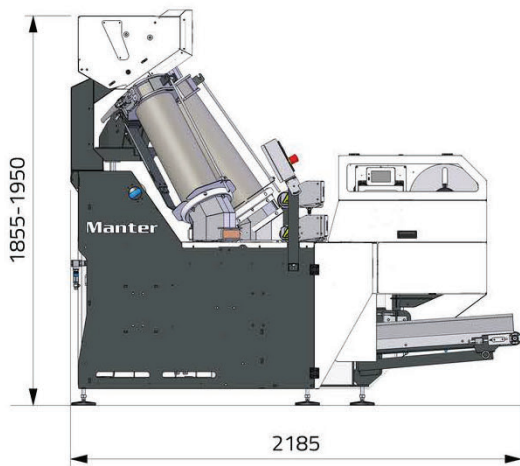

## Manter International B.V.

Phileas Foggstraat 66  
7825 AL Emmen  
The Netherlands

## Contact

Jason Brown  
+61 477 444 161  
jason.b@wymasolutions.com

